

GILMORE DYNAMID CONFIGURATION = BALANCED INPUTS, BALANCED OUTPUTS

SOURCE INTERCONNECTS INPUT JACK VOLUME CONTROL AMPLIFIER OUTPUT JACK HEADPHONE WIRING

SOURCE / OUTPUT / DAC MALE PANEL JACK (LOOKING IN) CABLE END FEMALE PLUG (LOOKING IN) DESTINATION / INPUT / AMP FEMALE PANEL JACK (LOOKING IN) FOUR AMPLIFIER CIRCUITS (SAME AS THE SOURCE XLR JACKS) OR USE AN AFTERMARKET CABLE or 1/4" MONO PHONO JACKS

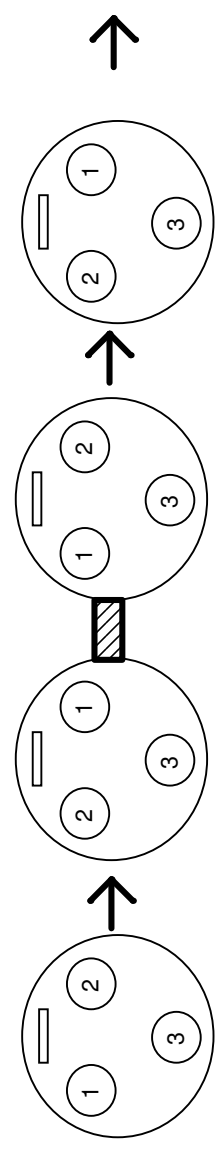

LEFT CHANNEL

- 1 = EARTH / GND / SHIELD
- 2 = NON-INVERTING SIGNAL
- 3 = INVERTING SIGNAL

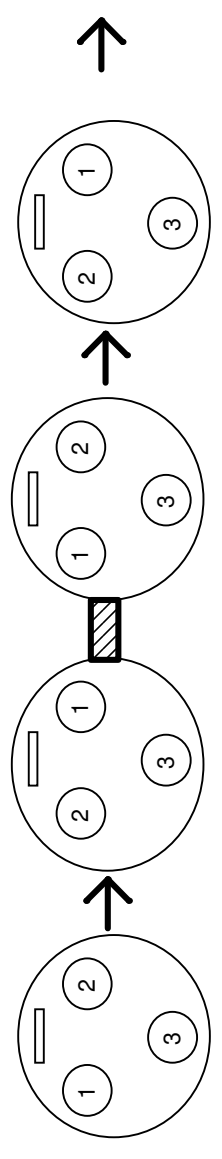

RIGHT CHANNEL

- 1 = EARTH / GND / SHIELD
- 2 = NON-INVERTING SIGNAL
- 3 = INVERTING SIGNAL

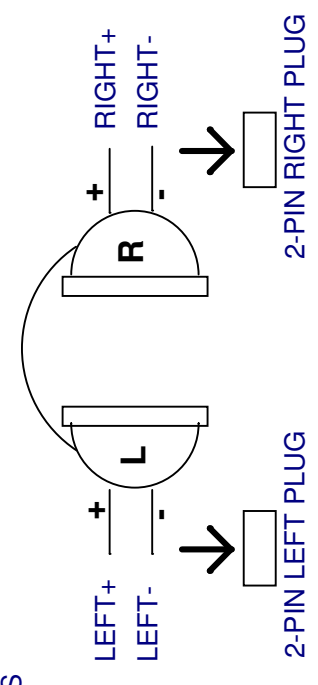
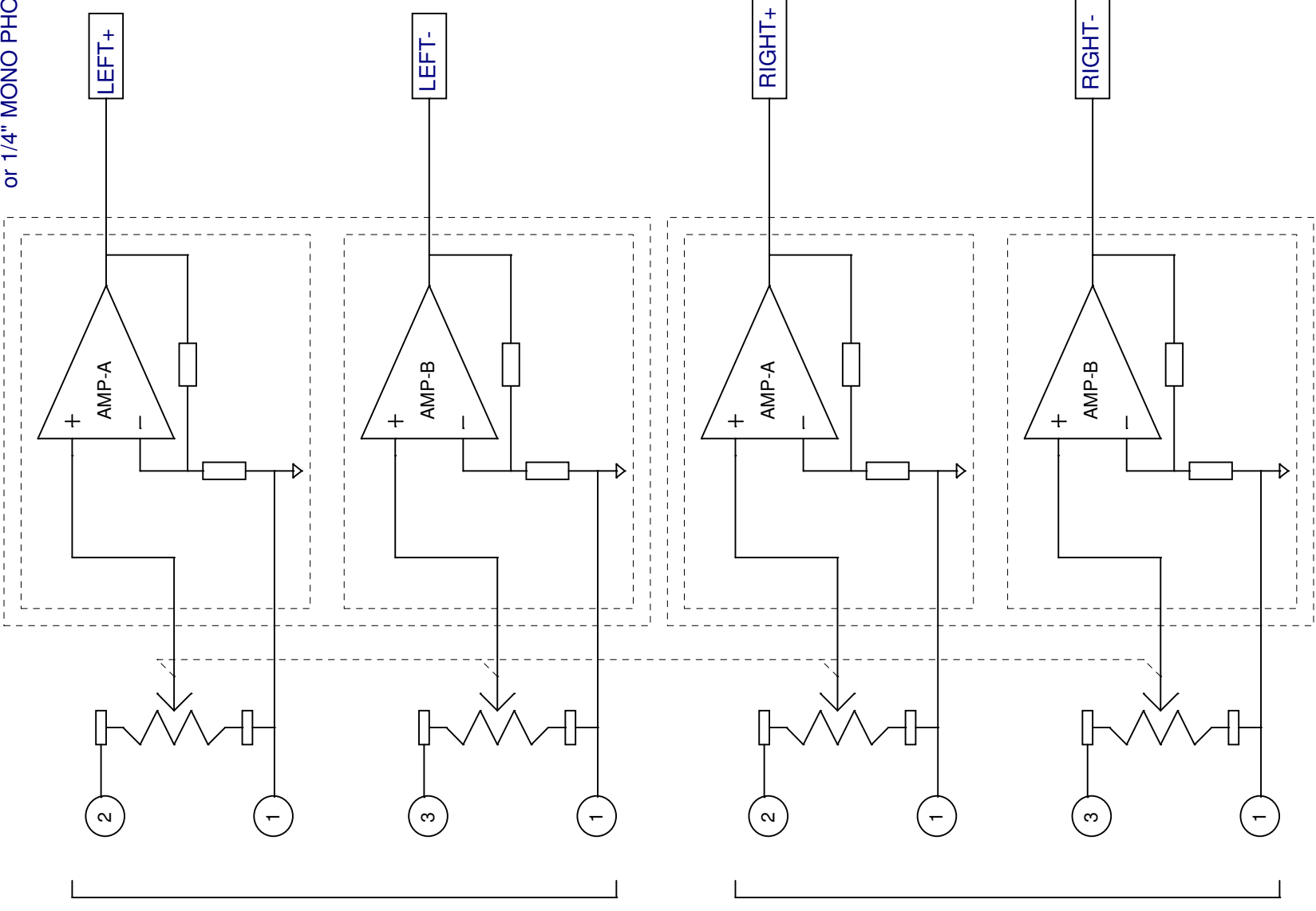

HEADPHONE PLUG OPTIONS

A PAIR OF 3-PIN FEMALE XLR PLUGS

HEAD PHONE CABLE FEMALE XLR PLUG (LOOKING IN)

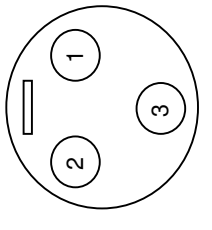

- 1 = NO CONNECT
- 2 = CHANNEL+
- 3 = CHANNEL-

A PAIR OF 1/4" TIP-SLEEVE (TS) PHONO PLUGS

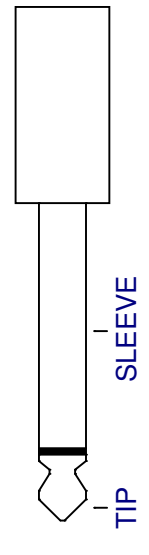

- TIP = CHANNEL +
- SLEEVE = CHANNEL-

Title		GILMORE DYNALO / DYNAMID AMPLIFIER	
Size	Document Number	Rev	
B	D.Gardner	A	
Date:	Saturday, November 13, 2004	Sheet	4 of 4